



VAL AVIONICS LTD

COM 2000

VHF Transceiver



Installation and Operator's Manual

Revision 4
December 2013

P/N 172200-4

VAL AVIONICS LTD
COM 2000 - VHF TRANSCEIVER
INSTALLATION AND OPERATOR'S MANUAL

Revision History:

- October 2010 – Initial Printing

- May 2012 – Inserted section 1.4: FCC regarding FCC ID and emissions.

- December 2012 – Updated Appendix A, table 4 with serial pin port. Spelling Corrections

- March 2013 – Updated Appendix A for units with serial number 20720 to current.

- December 2013 – Updated table of contents and formatting.
Removed AP-100 Wiring diagram
Changed section 9.5 and 9.6 to improve clarity.
Removed NAV 2000 / INS 429 commands from section 9.6
Added NAV 2000 wiring diagram for single serial port connection
Corrected mistake in table 4 (serial pins reversed)

**VAL AVIONICS LTD
COM 2000 - VHF TRANSCEIVER
INSTALLATION AND OPERATOR'S MANUAL**

Table of Contents

1	SECTION I - GENERAL INFORMATION	5
1.1	INTRODUCTION	5
1.2	SCOPE	5
1.3	EQUIPMENT DESCRIPTION	5
1.4	FCC	6
1.5	SPECIFICATIONS	7
1.6	EQUIPMENT SUPPLIED	8
1.7	EQUIPMENT REQUIRED BUT NOT SUPPLIED	8
1.8	LICENSE REQUIREMENTS	8
2	SECTION II - INSTALLATION	9
2.1	GENERAL INFORMATION	9
2.1.1	Scope	9
2.2	UNPACKING AND INSPECTION	9
2.3	EQUIPMENT INSTALLATION PROCEDURES	9
2.3.1	Cooling Requirements	9
2.3.2	Mounting Requirements	9
2.3.3	Wire Harness Fabrication	10
2.3.4	COM 2000 Installation	10
2.4	POST INSTALLATION CHECK	11
2.4.1	Operational Check	11
2.4.2	Final Inspection	11
2.5	LIMITATIONS	11
3	SECTION III - OPERATION	12
3.1	GENERAL INFORMATION	12
3.1.1	Scope	12
3.1.2	Display Functions	12
3.1.3	User Controls	12
3.2	System Configuration	14
3.2.1	Accessing Setup Functions	14
4	SECTION IV - WARRANTY AND SERVICE	15
4.1	LIMITED WARRANTY	15
4.2	SERVICE	15
5	Appendix A – INSTALLATION DRAWINGS AND CONNECTOR LAYOUT	16
6	Appendix B – WIRING DIAGRAMS	19
7	Appendix C – Certifications	21
7.1	TSO Certification:	21
8	Appendix D – INSTRUCTIONS FOR CONTINUED AIRWORTHINESS	22
8.1	MAINTENANCE INSTRUCTIONS	22
9	Appendix E – RS-232 Command Interface	23
9.1	Input Commands	23
9.2	Output Messages	23
9.3	Data Format	23
9.4	Default Message Output	23
9.5	Message Formats	24
9.6	Message Definitions	25

VAL AVIONICS LTD
COM 2000 - VHF TRANSCEIVER
INSTALLATION AND OPERATOR'S MANUAL

Table of Contents (cont.)

Table 1: Specifications	7
Table 2: Equipment Supplied	8
Table 3: Equipment Not Supplied	8
Table 4: Rear Connector Pin Functions (Serial number 20720 to current).....	18
Table 5: Rear Connector Pin Functions (Serial number 20500 to 20719).....	18
Table 6 - Data Output Requests.....	25
Figure 1: Unit Controls.....	12
Figure 2: Physical Dimensions	16
Figure 3: P1 Connector Pin Out.....	17
Figure 4: Panel Cut Out.....	17
Figure 5: Mounting Tray Assembly Exploded View.....	17
Figure 6: COM 2000 Basic Wiring Diagram.....	19
Figure 7: Single Serial Port Wiring Diagram	20

1 SECTION I - GENERAL INFORMATION

1.1 INTRODUCTION

Thank you for purchasing our COM 2000 – *VHF Transceiver*. Here at Val Avionics Ltd., our core design philosophy is based on the ease of installation and use. The COM 2000 represents 20 years of refinement in that process, based on the feedback of customers that have used the COM 760. The COM 2000 takes the original idea of the COM 760: a simple to use, reliable, and without the frills of other radios; Overhauled and incorporating new and exciting features.

That design philosophy translates into the ease of installation and simple operation makes the COM 2000 – *VHF Transceiver* a communication solution for a wide variety of aircraft panels, from the Homebuilt through heavy twins. The COM 2000 satisfies the need for compact, fully intergraded, quality radio that can be counted on to provide years of reliable service.

Before installing and /or using your new COM 2000 please read this manual completely. This will ensure proper installation and familiarize you with all of the features your COM has to offer.

1.2 SCOPE

This manual will provide detailed information about the installation and operation of the COM 2000 – *VHF Transceiver*. It will also provide equipment limitation information and instructions for continued airworthiness.

1.3 EQUIPMENT DESCRIPTION

The COM 2000 has been designed for simplicity. It is intuitive to install and operate. Using state of the art technology Val Avionics Ltd. has created a radio that will provide the pilot with simple and easy to operate communications.

The COM 2000 also has an enhanced display that features both active and standby frequency displays. As an added feature from the classing COM 760, the unit now features non-volatile memory for both the active and standby frequencies. No longer do you need a memory power line to maintain your frequencies. Also included is a revolutionary 15 channel quick access memory (The largest in the industry). The display also incorporates the latest in high intensity LED technology that provides excellent view ability even in direct sunlight.

The unit's controls have been designed for simple user interface. The concentric knobs on the right side of the unit select the standby frequency, with a push button flip-flop to load the standby frequency into the active window. The inner concentric knob on the left side of the unit selects the volume. The outer left knob controls the squelch allowing a pilot to quiet noisy channels, or receive weak signals, all from the twist of a knob. The push button on the left side knob set lets the user select a previously stored channel in memory. A long push of the left button will power the unit down.

The COM 2000 has one internal receiver. The internal receiver operating from 118.00 MHz to 137.975 MHz. This receiver is capable of receiving down to 2 μ V with a 6dB signal to noise ratio.

The COM 2000 has many audio inputs and outputs to facilitate any installation. The unit has 2 capacitively coupled audio inputs for adding a Nav receiver audio output or other such audio device. The COM also has a 5W speaker output and 50mW headphone output.

VAL AVIONICS LTD
COM 2000 - VHF TRANSCEIVER
INSTALLATION AND OPERATOR'S MANUAL

1.4 FCC

The COM 2000 transceiver is a Voice Modulated communications device utilizing Amplitude modulation, with a maximum power of 10W, operating in the **6K00A3E** emission designator, with a 25kHz channel spacing.

This unit has been tested and found to comply with the limits for a Class B receiver, pursuant to Part 15 of the FCC rules, as well as the emission requirements set forth in Part 87 of the FCC rules. These limits are designed to provide reasonable protection against harmful interference when it is operated in an aircraft environment. The unit generates, uses and can radiate radio frequency energy and, if not installed and used in accordance with the instructions manual, may cause harmful interference to radio communications. Operation of the unit in a residential area is likely to cause harmful interference in which case the user will be required to correct the interference at his own expense.

FCC ID: EZN5PRCOM2000

VAL AVIONICS LTD
COM 2000 - VHF TRANSCEIVER
INSTALLATION AND OPERATOR'S MANUAL

1.5 SPECIFICATIONS

Table 1: Specifications

SPECIFICATIONS	CHARACTERISTICS
Environmental:	(RTCA/DO160D)
Minimum Performance Standard	(RTCA/DO-186B)
Physical Dimensions:	
Height	1.0 inches (2.54 cm)
Width	6.25 inches (15.88 cm)
Depth	9.0 inches (22.86 cm)
Weight:	3.25 pounds (1.5 kg)
Mounting:	Panel mounted, no shock mounting required
Temperature Range:	-20 to +55 Celsius with short time operations at +70 Celsius
Power Requirements:	
Voltage	11.0 to 30.0 VDC
Current	0.5 Amp Rec. 3 Amp max transmit
Receiver:	
VHF Frequency	118.00 to 136.975 MHz
Sensitivity	2 μ V to provide a 6dB S+N:N
Channel Spacing	25 kHz
Stability	\pm .002%
Selectivity	\geq 60dB
Audio output	5W to 4 Ω Spk 50mW to 600 Ω Phone
AGC Characteristics	From 10 μ V to 200 μ V the audio level will not vary more than 3db.
Transmitter:	
Carrier Power	8W nom. RMS
Duty Cycle	50%
Manufacturer's Model Number	COM 2000
Part Number	VPN 0800105

**VAL AVIONICS LTD
COM 2000 - VHF TRANSCEIVER
INSTALLATION AND OPERATOR'S MANUAL**

1.6 EQUIPMENT SUPPLIED

Table 2: Equipment Supplied

QTY	DESCRIPTION	PART NUMBER
1	COM 2000 – 760 Channel Radio	0800105
1	INSTALLATION KIT	651002

1.7 EQUIPMENT REQUIRED BUT NOT SUPPLIED

Table 3: Equipment Not Supplied

QTY	DESCRIPTION	PART NUMBER
1	Circuit Breaker 5 amp	Potter & Brumsfield W58-2 (Ref VPN 0331005)
1	Aircraft Cabin Speaker	Ref aircraft parts manual for specific part number
1	Contact Crimping Tool w/ Positioning Tool	AMP P/N 601966-1 AMP P/N 601699-5

1.8 LICENSE REQUIREMENTS

None

2 SECTION II - INSTALLATION

2.1 GENERAL INFORMATION

2.1.1 Scope

This section of the manual will provide the needed information to successfully complete the installation of your new COM 2000 – *VHF Transceiver*. Please read this section completely before proceeding with the installation process. Although the COM 2000 installation procedures are designed with the do-it-yourselfer in mind, we at Val Avionics Ltd. strongly suggest that you seek the advice of a qualified avionics installation facility before beginning this or any other installation project. Qualified avionics installation technicians can offer good advice as to time-tested installation practices and techniques that can save you many hours of time and frustration.

2.2 UNPACKING AND INSPECTION

Use care when unpacking the equipment. Inspect the unit and supplied parts for visual signs of damage during shipment. Examine the unit for loose screws, dents, broken buttons and other signs of damage that may have occurred during shipment. Verify the contents of the container with the list in section 1.5. If any damaged or missing parts are discovered during the inspection save the shipping material and contact the freight carrier to file a claim. If it is suspected that parts were omitted from the container please feel free to contact Val Avionics Ltd., to acquire the missing items.

2.3 EQUIPMENT INSTALLATION PROCEDURES

2.3.1 Cooling Requirements

Forced air-cooling is not required for the COM 2000 – *VHF Transceiver*. However, when planning the location for mounting, ensure adequate spacing from heat producing sources such as heating or defrosting ducts.

2.3.2 Mounting Requirements

The COM 2000 mounting tray should be rigidly mounted in the avionics stack using the hardware provided in the installation kit. Ensure that the mounting location will provide easy access and a clear view of the equipment's front panel from the pilot's position. Ensure that the mounting position will provide adequate clearance between the unit and the associated wire harness and the aircraft controls. Bracing at the rear of the unit should be installed to ensure rigidity in the panel. Consult FAA Advisory Circular AC 43.13-2A for acceptable practices and techniques.

2.3.3 Wire Harness Fabrication

Val Avionics Ltd. Strongly recommends the use of a factory fabricated wire harness (VPN 751027) with your new COM 2000 – *VHF Transceiver*. Use of the factory fabricated wire harness will ensure proper operation of the COM 2000, reduction in the occurrence of interfering signals and ground loops, greatly reduced installation time, and provide prolonged trouble-free performance of your new equipment.

Although strongly recommended, it is not required to use the factory fabricated wire harness when installing the COM 2000. A wiring harness can be fabricated in the field. Refer to appendix B of this manual for a complete wiring diagram. The COM 2000 is connected to the aircrafts avionics bus via a 5 AMP circuit breaker. All wires must be 22 AWG MIL-SPEC, unless otherwise noted in accordance with current regulations. Two and three conductor shielded MIL-C-27500 or equivalent wire must be used where indicated. Use AMP Contact Crimping Tool (AMP P/N 601966-1) with Positioning Tool (AMP P/N 601699-5) or equivalent to ensure good quality contacts. Refer to FAA Advisory Circular AC 43.13-2A for acceptable practices and techniques.

2.3.4 COM 2000 Installation

2.3.4.1 Mounting

The COM 2000 is rigidly mounted in the aircrafts avionics stack. Once a location has been selected, a visual inspection should be made of the area directly behind the panel which, will be occupied by the COM 2000 and harness assembly for obvious obstructions such as heater ducts, control cables, fuel and oil lines or any other obstruction. Pay particular attention to the control yoke assembly. It should be moved to the full limit of travel and verified that sufficient clearance exists prior to beginning installation. Most aircraft instrument panels will already have existing radio mounting cutouts. If the location you have selected requires that a mounting hole be cut, refer to Figure 4: Panel Cut Out on Page 17 for the mounting template. Mark and cut the mounting holes as required.

Position the unit's mounting tray in its upright position, and from the rear of the panel. With the unit held in place, insert the two of the supplied 6-32 X 3/8" screws from the front and tighten as appropriate. The installing agency must fabricate and attach rear support brackets to the aircraft structure behind instrument panel as appropriate to support the rear of the COM 2000. Then, attach these brackets to the provided attachment points on the rear of the unit with the supplied 6-32 1/4" Screws.

2.3.4.2 Antennas

One antenna is required for the COM 2000 installation. A standard COM antenna can be used with the unit such as a COMANT CI-121 or equivalent. Follow the antenna manufacture's installation Manual to ensure proper installation of the antenna.

2.3.4.3 Audio

The COM 2000 has two auxiliary audio inputs and two audio outputs, Speaker audio and Headset audio. In installations with two radio and/or more audio devices, it is strongly recommended that these audios be coupled to a quality audio selector panel such as a Val Avionics AP 100. For complete details, refer to the interconnect wiring diagrams in Appendix B.

2.4 POST INSTALLATION CHECK

2.4.1 Operational Check

Refer to section three of this manual. Check all functions of the COM 2000 for proper operation. Check the operational functions of other equipment installed in the aircraft in accordance with the individual manufacture's operation manuals to insure that no cross interference exists as a result of this installation.

2.4.2 Final Inspection

Verify that the wiring is bundled away from all controls and that no part of the installation interferes with the movement of the aircraft controls. Move all of the aircraft controls through their full range of movement while visually verifying that the installation does not mechanically interfere with the control movement. Verify that the wiring harnesses are properly secured to the aircraft structure in accordance with accepted practices as described in AC 43.13 and that adequate strain relief and service loops have been provided. Ensure that there are no kinks or sharp bends in the wire harnesses. Verify that the wire bundles are not exposed to any sharp or abrasive surfaces. Complete log book entries, FAA form 337, weight and balance computations and other documentations as required.

2.5 LIMITATIONS

There are no known limitations to the operation of the COM 2000. Instructions for Continued Airworthiness and Return to Service Instructions can be found in Appendix C.

3 SECTION III - OPERATION

3.1 GENERAL INFORMATION

3.1.1 Scope

This section will provide detailed operating instructions for your new COM 2000 – *VHF Transceiver*. Please read this section completely to become familiar with all of the features of the unit.



Figure 1: Unit Controls

3.1.2 Display Functions

Upon power up the unit will display initialization codes. After initialization, the unit will display an active and standby frequency represented by “Axxx.xxx Sxxx.xxx” with the x’s representing the frequency. The first frequency starting with the “A” is the active frequency, and the “S” is the standby frequency. When the unit is transmitting the “A” will be replaced with a “T” to represent active transmit. When the unit is selecting a memory station, the “A” and “S” will no longer be visible and the active portion will contain the seven-character description and the standby will contain the frequency associated with the description.

3.1.3 User Controls

Refer to Figure 1: Unit Controls. The user controls consist of two sets of concentric rotary knobs. Both sets of knobs contain three parts, the inner knob (the small one) the outer knob (the large one) and a momentary push button (the end of the small knob). The left outer inner knob controls the squelch as well as the position of the cursor in memory edit. The left inner knob controls the volume, allows for selection of a stored memory, and selects characters in memory edit. The right knobs control the frequency, whether it is the standby frequency or entering the memory frequency.

3.1.3.1 Turning the unit on/off

To turn the unit on, momentarily press the left hand inner knob. The unit will go through a short initialization routine at start up and then begin operation at the same settings that were loaded at the last power down. To turn the unit off, press and hold the left inner knob for three seconds.

3.1.3.2 Setting Active and Standby Frequency

The knob functions of the right hand set are as follow; the inner knob will change the frequency by KHz or the numbers to the right of the decimal point (118.**125**) in 25kHz increments. The outer knob will change the frequency by MHz or the numbers to the left of the decimal point (**119**.125) in 1 MHz increments. Only the frequency in the standby position will change. The standby frequency is displayed at the bottom on the left side of the display and is identified by the letter "S" to the left of the frequency (S108.15). To load the standby frequency in to the active position, momentarily press on the inner knob. This will swap the standby frequency with the active frequency. The active frequency is identified by the letter "A" at the left of the frequency display (A118.125).

3.1.3.3 Changing the Volume

Rotating the left hand inner knob controls the receiver's audio volume. "VOL" will be displayed in the standby frequency display and the volume level is indicated by the numeric value after "VOL" (i.e. "VOL 15"). The volume level can be adjusted from 0 to 20 by rotating the left hand inner knob. Normal display operation resumes after 2 seconds.

3.1.3.4 Changing the Minimum Received Signal Level (Squelch)

Rotating the left hand outer knob controls the receiver's internal signal strength cutoff (Squelch). "SQL" will be displayed in the standby frequency display and the volume level is indicated by the numeric value after "SQL" (i.e. "SQL 15"). The squelch level can be adjusted from OFF to 20 by rotating the left hand inner knob. Normal display operation resumes after 2 seconds.

3.1.3.5 Selecting a Stored Memory Station

A quick push of the left hand knob enters the stored station retrieval. If no memory stations are available, the display will show "NO MEM" and return to normal operation. Rotating the inner left hand knob scrolls through the previously entered memory stations. In the left side (previously the active display) the pre-programmed label will be shown, and the right side (previously the standby display) will show the associated frequency. Once the desired frequency is displayed, a quick push of the left hand knob will cause the selected frequency to be loaded into the Standby window and the unit will return to normal operation. To exit without selecting a memory frequency, just wait 5 seconds without twisting any knob and the display will return to normal, or push the right hand knob to exit instantly.

3.1.3.6 Entering / Editing / Deleting a Stored Memory Station

Val Avionics does not recommend entering or editing stored frequencies in flight. Doing so can be a distraction to the pilot.

3.1.3.6.1 Selecting a stored frequency to be created / edited /deleted

By pushing both left and right buttons, the unit will enter the stored frequency edit select mode. If there are no frequencies entered, or the unit is selecting an open memory slot, the unit will show no text in the active window, and the standby will display "<EMPTY>". When adding a new frequency, rotate the inner left knob until the display shows ""<EMPTY>". To edit a currently existing frequency, rotate to the frequency / station label that is to be edited.

3.1.3.6.2 Creating / Editing a stored frequency

Depress the left hand button to enter the edit mode, which is characterized by a blinking cursor at the leftmost position of the label text. By rotating the left inner knob, a new character can be selected for the memory location. By rotating the left outer knob, the position of the cursor can be changed. Once the label has been entered, rotating the right knobs will allow for the frequency to be selected. When the data is entered as desired, pressing the left hand button will exit the edit mode and return to the previous state. If desired, additional frequencies can be edited or added by repeating the above steps.

3.1.3.6.3 Deleting a Stored frequency

Once the undesired frequency has been selected (see 3.1.3.6.1), press the right hand knob. A confirmation will appear in the Standby window, rotate the left hand inner knob to select “Y”, and press the right hand knob to confirm. This deletes the stored information.

3.1.3.6.4 Exiting the stored frequency editing functions

To exit and return to normal operation, pressing both buttons will return to normal operation.

3.2 System Configuration

3.2.1 Accessing Setup Functions

During startup, the unit's setup can be assessed by pressing both buttons simultaneously until the unit shows an active frequency and “MicG xx”. In this mode, the Microphone Gain and Sidetone values can be configured. In this mode, the unit will transmit and receive any frequency that is located in the active window and the frequency knobs (right hand inner and outer) will directly control the active frequency. The left hand inner knob adjusts the Microphone gain, and the left hand outer knob adjusts the Sidetone. To exit this mode and resume normal operation, press both buttons simultaneously.

4 SECTION IV - WARRANTY AND SERVICE

4.1 LIMITED WARRANTY

The equipment delivered with this Standard Factory Warranty is manufactured by Val Avionics, Ltd. and is guaranteed against defective materials and workmanship for one year from date of original retail purchase. Any unit found to be defective due to material and workmanship during the warranty period will be repaired or replaced at the sole discretion of Val Avionics Ltd.

Val Avionics, LTD liability under this warranty is limited to servicing, repairing or adjusting any equipment returned prepaid to the Val Avionics' factory by express written or verbal authorization for that purpose and to repair or replace defective parts thereof.

If, upon examination, it is determined that a malfunction has been caused by misuse of the equipment, installation or operation not in accordance with factory instructions, accident or negligent damage, alterations of any manner, and repair by other than the factory, the repairs will not be covered under the warranty. In such cases, an estimate will be submitted for approval before repair is initiated. In most cases, Val avionics, Ltd. will provide 72-hour turn around on its warranty and repair service. We recommend that contact be made with the FACTORY CUSTOMER SERVICE DEPARTMENT prior to any unit return and obtain RETURN AUTHORIZATION AND INSTRUCTIONS. This will provide proper control and expedite service.

Val Avionics, Ltd. reserves the right of continuous product development without obligation to install changes in previously manufactured products.

Installation of Val Avionics, Ltd. products must conform to methods acceptable by the Federal Aviation Administration as described in the appropriate Federal Aviation Regulations (FAR's) and Advisory Circulars (AC's).

To ensure proper warranty registration, type or print clearly the application information on the enclosed PRODUCTS WARRANTY REGISTRATION FORM and return to Val Avionics, Ltd.

4.2 SERVICE

Repair service for the COM 2000 – *VHF Transceiver* is available at our manufacturing facility. Units in need of servicing should be returned prepaid to Val Avionics Ltd at the following addresses.

If you are shipping by the US Postal Service address To:

Val Avionics
P.O. Box 13025
Salem, OR 97309

If you are shipping by FedEx, UPS or other shipping company, address to:

Val Avionics
2950 Pringle Road SE
Salem, OR 97302

5 Appendix A – INSTALLATION DRAWINGS AND CONNECTOR LAYOUT

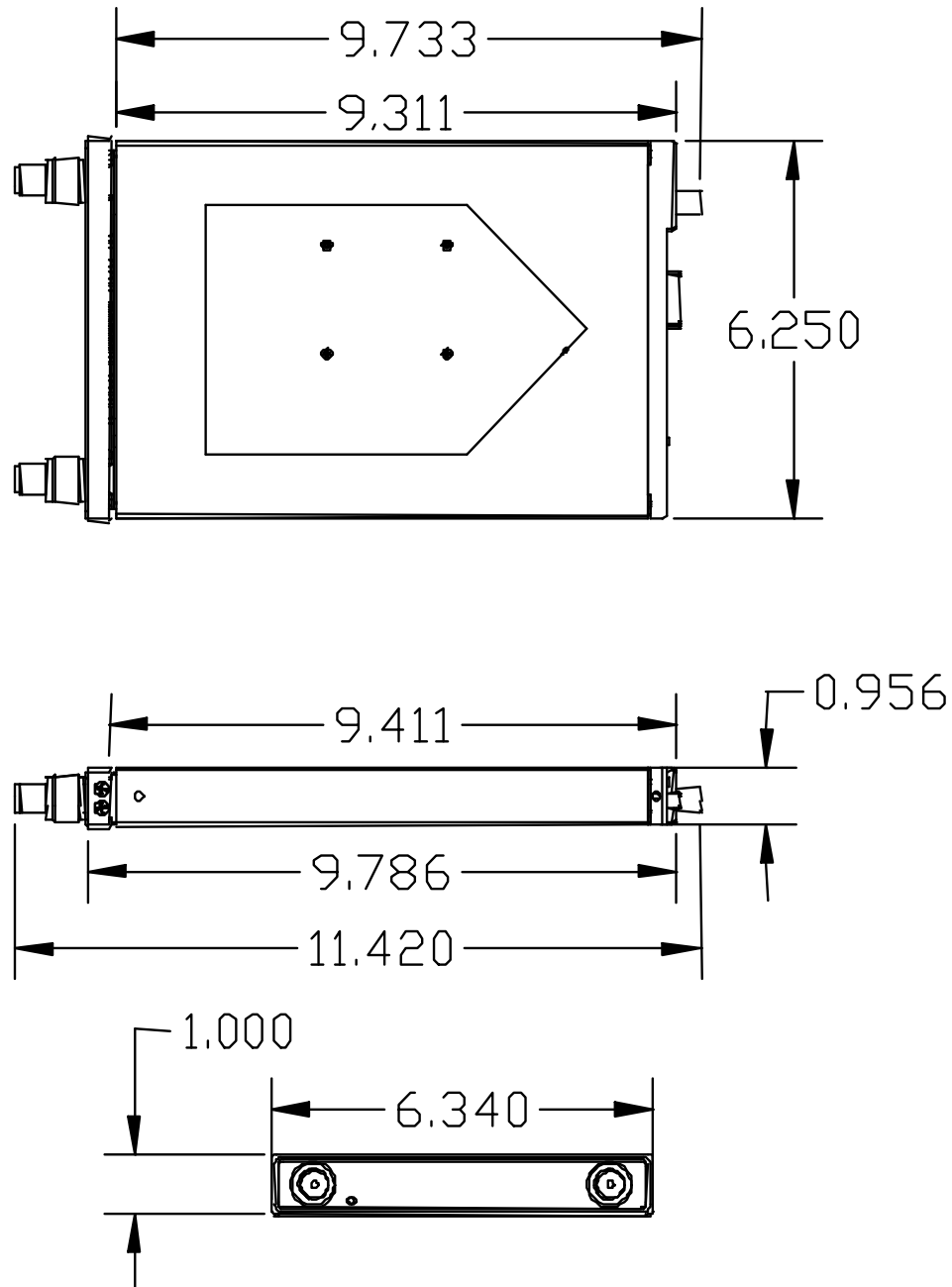

Figure 2: Physical Dimensions

VAL AVIONICS LTD
COM 2000 - VHF TRANSCEIVER
INSTALLATION AND OPERATOR'S MANUAL

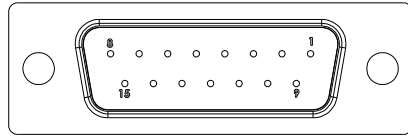
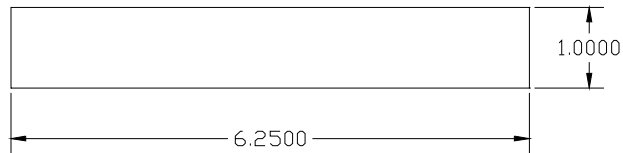

Figure 3: P1 Connector Pin Out



(Drawing Not to Scale)

Figure 4: Panel Cut Out

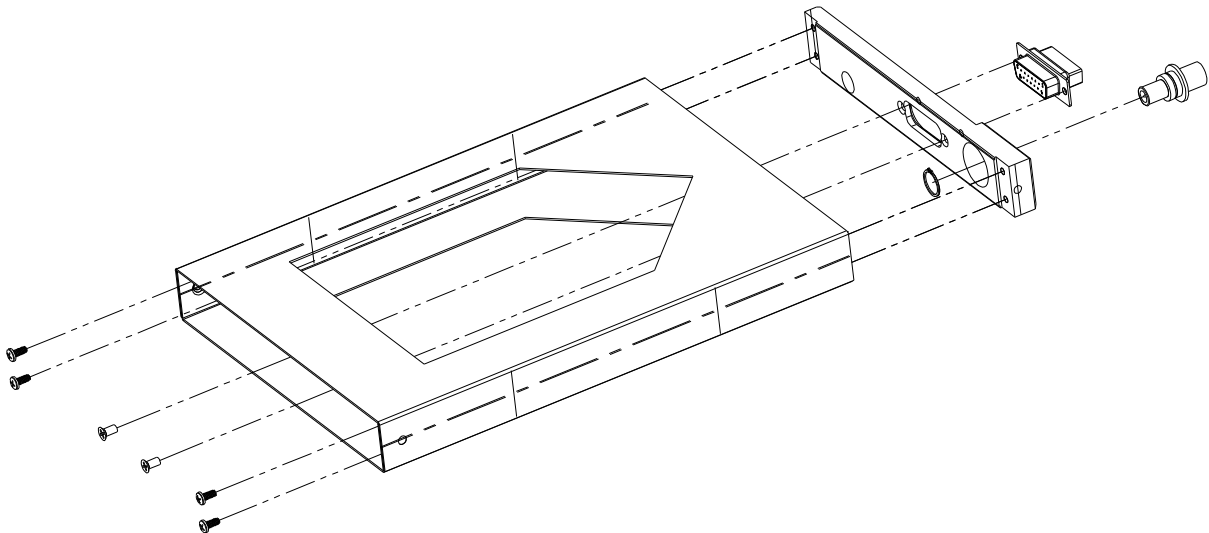

Figure 5: Mounting Tray Assembly Exploded View

VAL AVIONICS LTD
COM 2000 - VHF TRANSCEIVER
INSTALLATION AND OPERATOR'S MANUAL

Table 4: Rear Connector Pin Functions (Serial number 20720 to current)

Pin	Function	I/O
1	RS-232 In	Input
2	Aux In 2	Input
3	Speaker Ground	
4	Headphone Ground	
5	Mic Ground	
6	Key	Input
7	Main Ground	
8	Main Power	
9	RS-232 Out	Output
10	Aux In 1	Input
11	Speaker	Output
12	Headphone	Output
13	Mic Audio	Input
14	Active/Standby Toggle	Input
15	NC	

Table 5: Rear Connector Pin Functions (Serial number 20500 to 20719)

Pin	Function	I/O
1	RS-232 In	Input
2	Aux In 2	Input
3	Speaker Ground	
4	Headphone Ground	
5	Mic Ground	
6	Key	Input
7	Main Ground	
8	Main Power	
9	RS-232 Out	Output
10	Aux In 1	Input
11	Speaker	Output
12	Headphone	Output
13	Mic Audio	Input
14	Main Ground	N.F.N.I.
15	Main Power	N.F.N.I.

(N.F.N.I) – Not for new Installation – To maintain compatibility with new units, do not use pins 14 and 15 for the unit main power and ground.

6 Appendix B – WIRING DIAGRAMS

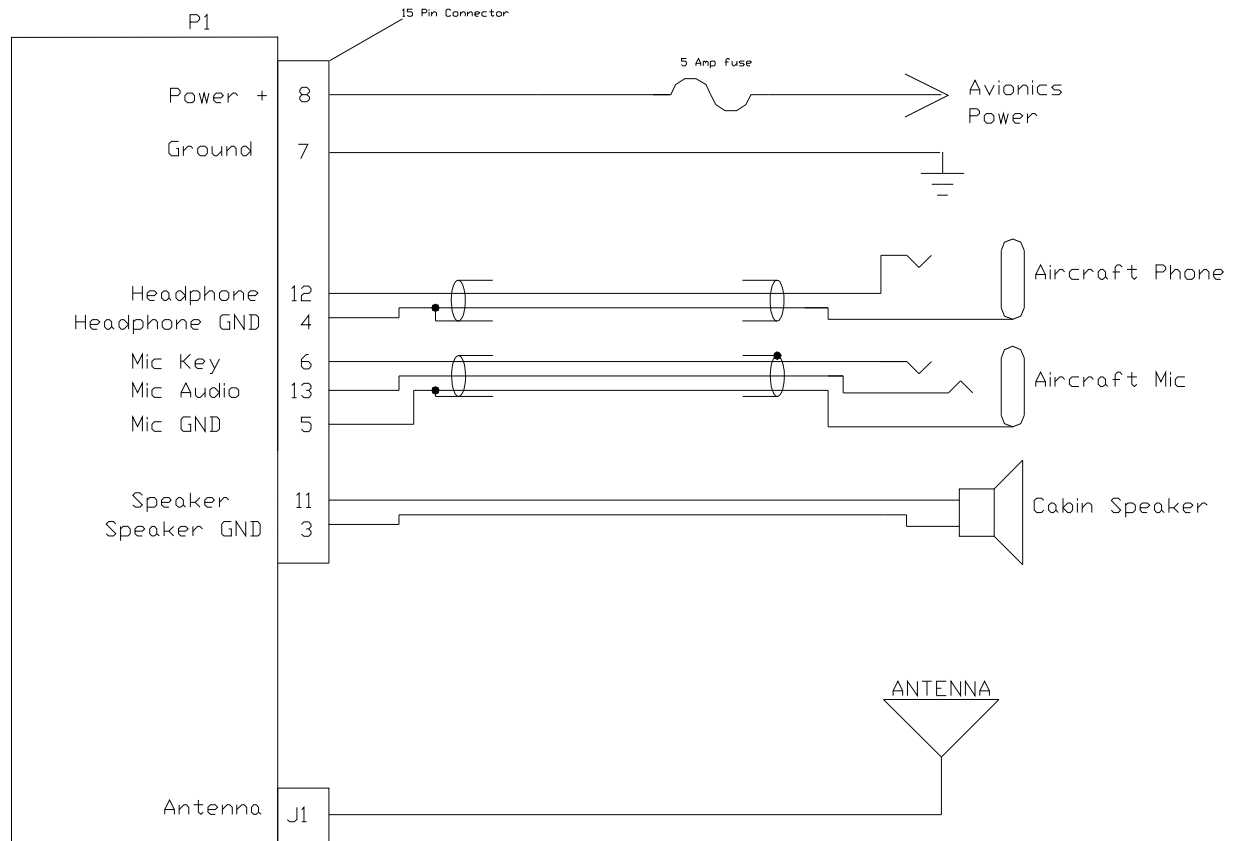

Figure 6: COM 2000 Basic Wiring Diagram

VAL AVIONICS LTD
COM 2000 - VHF TRANSCEIVER
INSTALLATION AND OPERATOR'S MANUAL

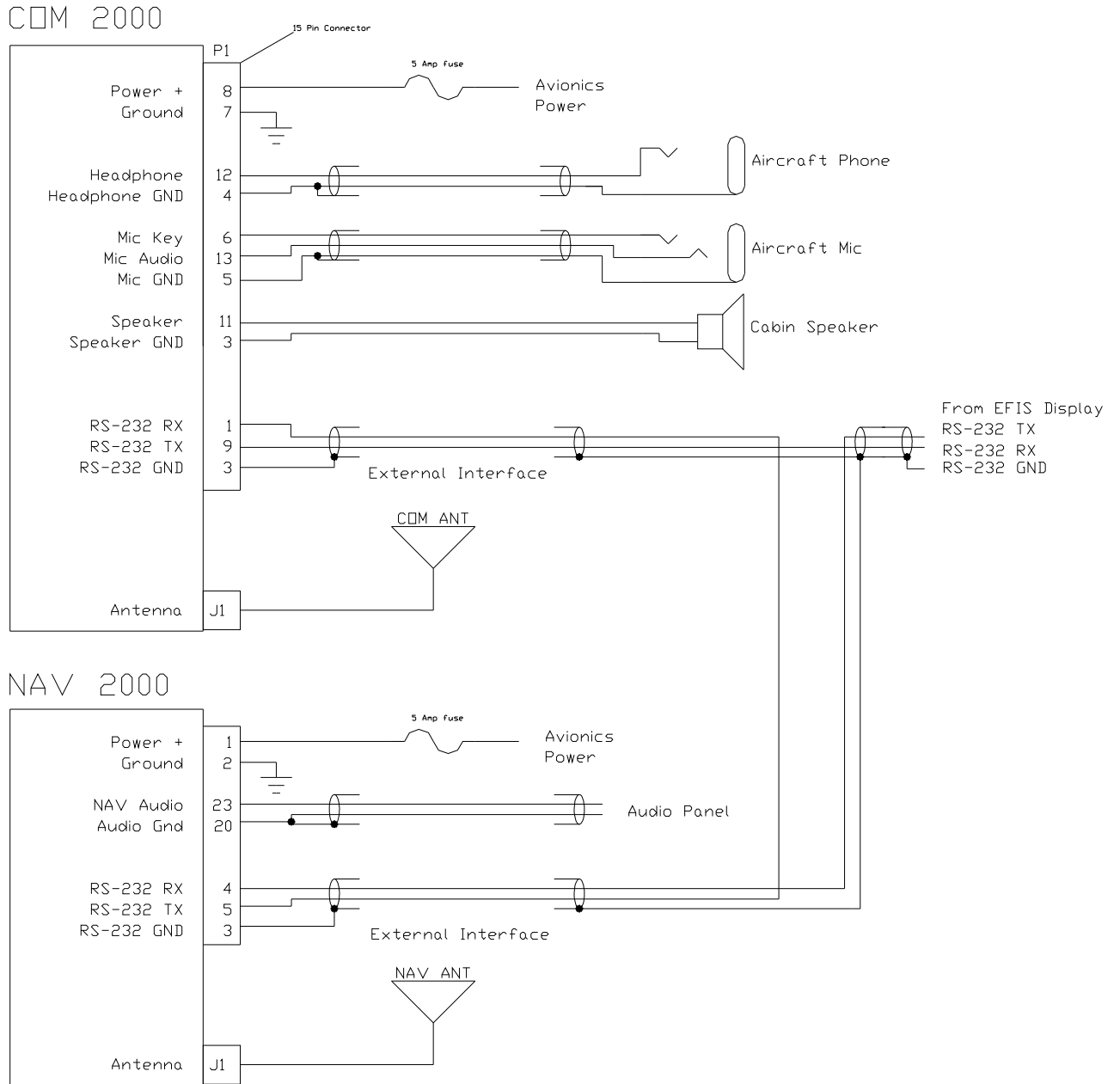

Figure 7: Single Serial Port Wiring Diagram

7 Appendix C – Certifications

7.1 TSO Certification:

This device has been tested and found to meet specification of TSO-C169a.

8 **Appendix D** – INSTRUCTIONS FOR CONTINUED AIRWORTHINESS

8.1 MAINTENANCE INSTRUCTIONS

Maintenance of the COM 2000 – *VHF Transceiver* is on condition only. **No periodic maintenance is required.** If unit is found to be out of calibration, send unit in for service. If unit is removed for service, upon re-installation perform Post Installation check as described in section 2.4 of this manual.

9 Appendix E – RS-232 Command Interface

This appendix includes the interface specifications for the RS-232 serial port. The RS-232 port can be used to input active and standby frequencies as well as using an external serial resolver such as an EFIS system. The interface format conforms to NMEA 0183 message format specifications. For improved compatibility, the COM 2000 / COM 2KR accepts all commands for the INS 429 / NAV 2000 / NAV 2KR

9.1 Input Commands

The following input command messages are supported:

- Request data output
- Set active COM frequency data from a remote source
- Set standby COM frequency data from a remote source
- Set COM Volume and Squelch Level
- Set COM Mic Gain and Sidetone

9.2 Output Messages

The COM 2000 / COM 2KR output messages include:

- Reset status
- Communications Error
- COM Receiver status
- COM audio mode
- COM microcontroller software version
- COM Volume and Squelch Level
- COM Mic Gain and Sidetone

9.3 Data Format

The data format for serial communication is:

- Baud rate 9600
- Data bits 8
- Stop bits 1
- Parity none

9.4 Default Message Output

At system start when the COM 2000 / COM 2KR is configured to operate in normal mode, the following messages will be configured for output and the specified rates:

- COM Receiver status at 1 Hz (low rate)

These default rates can be changed by using the Request Data Output message.

9.5 Message Formats

All messages will conform to the NMEA 0183 proprietary message format as follows. All characters will be standard ASCII characters. No binary data characters will be used.

“\$”	Start of message character, ASCII “\$” (024h)
“P”	Proprietary message identifier
“MRR”	II Morrow company identifier
c	Message class identifier. Used to identify a message as either a COMM or VHF NAV message. The COM 2000 can accept either the “V” or “C” message command to facilitate operation as a stand alone unit or as part of a emulated SL 30 unit.
nn	Message identifier, two-digit number in ASCII characters.
d...d	Message data characters defined for each message.
chksum	Message checksum, including message identifier through data characters. The two-digit checksum is generated by adding all values of valid characters together, ignoring carry (if any). This value is converted into two encoded hex ¹ characters (30h-3Fh).
<CR>	ASCII carriage return (0Dh)
<LF>	ASCII line feed (0Ah)

The maximum message length, including the start of message character (“\$”) and the end of message <CR><LF> sequence, is 25 bytes.

This message format is the same as is used in the INS 429 / NAV 2000 / NAV 2KR. The COM 2000 / COM 2KR will be able to accept all messages intended for a INS 429 / NAV 2000 / NAV 2KR without generating a serial communications error. It will ignore all of those messages.

¹ Encoded Hex: each character consists of 4 bits of data placed in the low order nibble +30h. For example, the 8-bit value of 5Fh would be encoded as two characters with values of 35h and 3Fh, which map to the ASCII characters “5” and “?” respectively.

9.6 Message Definitions

Input Messages

REQUEST DATA OUTPUT

This input is used to request an output message to be sent by the COM 2000 / COM 2KR.

Message format:

- "V"Message class. This is a VHF NAV message.
- "24"Message identifier.
- iiOutput identifier of requested message, two ASCII characters.
- dd.....Message data, two encoded hex² characters (30h-3Fh), used for specific output request. Set to "00" if not needed. These characters are used for such items as selecting a specific EEPROM address to output.
- A.....Request type: (ASCII) "0"= output repeatedly at low speed (1 Hz); "H" = output repeatedly at high speed (10 Hz).

ii	Output	Dd	Data Description	a
"20"	Reset Status	"00"		"0"
"35"	Comm Transceiver Status	"00"		"0", "L"
"36"	Comm Software Version	"00"		"0"
"71"	Comm Volume and Squelch	"00"		"0"
"72"	Comm Mic Gain and Sidetone	"00"		"0"

Table 6 - Data Output Requests

Example messages:

\$PMRRV2435000<chksm><CR><LF>

Request a single output of com transceiver status.

² Encoded Hex: each character consists of 4 bits of data placed in the low order nibble +30h. For example, the 8-bit value of 5Fh would be encoded as two characters with values of 35h and 3Fh, which map to the ASCII characters "5" and "?" respectively.

SET STANDBY COMM FREQUENCY AND TRANSRECEIVER FUNCTION

This message is issued to set the standby COM frequency.

Message format:

“V” Message class. This is a VHF NAV message.

“29” Message identifier.

Mk Standby COM frequency:

m = desired frequency in MHz in hexadecimal, where m = desired frequency - 30h, with desired frequency in range of 118 to 136 MHz, or 162 MHz.

k = desired frequency in kHz, where k = (desired frequency / 25 kHz) + 30h, with desired frequency in range of 000 to 975 kHz in 25 kHz steps.

a Transceiver function: N = normal, 0 = unchanged.

Example message:

```
$PMRRV29G4M<chk sm><CR><LF>
```

This example command would set the standby VOR frequency to 119.100 MHz. This is interpreted by noting that the ASCII ‘G’ corresponds with 47h, + 30h = 77h, converted to decimal equals 119 for the MHz portions. The kHz portion converts ASCII ‘4’ to 34h, - 30h yields 4h x 25 kHz steps = 100 kHz.

Note: The COM 2000 will check input frequencies for validity. An RS-232 serial error message output will be generated if the frequency is invalid.

SET ACTIVE COMM FREQUENCY AND TRANSCEIVER FUNCTION

This message is used to set the Active COM frequency as well as the COM transceiver function.

This message is only available in normal mode.

Message format:

“V” Message class. This is a VHF NAV message.

“42” Message identifier.

mk Active COMM frequency:

m = desired frequency in MHz in hexadecimal, where m = desired frequency - 30h, with desired frequency in range of 118 to 136MHz, or 162MHz.

k = desired frequency in kHz, where k = (desired frequency / 25kHz steps.)

a = Transceiver function: N = normal, 0 = unchanged.

Example message:

```
$PMRRV42G4N<chk sm><CR><LF>
```

This example command would set the active VOR frequency to 119.100MHz and place the COMM radio in Normal receive mode. This is interpreted by noting that the ASCII ‘G’ corresponds with 47h, + 30h = 77h, converted to decimal equals 119 for the MHz portion. The KHz portion converts ASCII ‘4’ to 34h, - 30h yields 4h, x 25KHz steps = 100 kHz.

Note: The COM 2000 will check input frequencies for validity. An RS-232 serial error message output will be generated if the frequency is invalid.

VOLUME AND SQUELCH CONTROL

This message is used to adjust the volume and squelch levels of the COM unit

VAL AVIONICS LTD
INS 429 INTEGRATED NAVIGATION SYSTEM
INSTALLATION AND OPERATOR'S MANUAL

Message format:

"V" Message class - VHF NAV Message
"71" Message Identifier
"vs" Volume level and Squelch Level:
 v = Desired volume level in encoded hexadecimal, where v = desired level + 0x30 with a range between 0 - 20, 0 being muted
 s = Desired squelch level in encoded hexadecimal, where s = desired level + 0x30 with a range between 0 - 20, 0 being off

Example Message:

\$PMRRV71;?<checksum><CR><LF>

This example command would set the volume level at 11 and the squelch at 15.

MIC GAIN AND SIDETONE CONTROL

This message is used to adjust the volume and squelch levels of the COM unit

Message format:

"V" Message class - VHF NAV Message
"72" Message Identifier
"ms" Volume level and Squelch Level:
 m = Desired mic gain level in encoded hexadecimal, where m = desired level + 0x30 with a range between 1 - 20
 s = Desired sidetone level in encoded hexadecimal, where s = desired level + 0x30 with a range between 1 - 20.

Example Message:

\$PMRRV72;?<checksum><CR><LF>

This example command would set the mic gain level at 11 and the sidetone at 15.

OUTPUT MESSAGES

RESET STATUS

This message is sent to indicate to the host that the INS 429 / NAV 2000 / COM 2000 / COM 2KR is running and ready to accept data on the serial port. It will be sent once upon startup and when requested by the host.

Message format:

“V”.....Message class. This is a VHF NAV message.
“20”.....Message identifier.

Example message:

```
$PMRRV20<chk sm><CR><LF>
```

COM 2000 / COM 2KR / NAV 2000 / INS 429 is running and ready to accept serial input.

COMMUNICATIONS ERROR

This message is used to indicate a communication error.

Message format:

“V”..... Message class. This is a VHF NAV message.
“27”..... Message identifier.
e..... Error code: (ASCII)
 “0” = input message checksum error.
 “1” = unknown message.
 “2” = error or mismatch in message data.

Example message:

```
$PMRRV271<chk sm><CR><LF>
```

Received an unknown message.

VAL AVIONICS LTD
INS 429 INTEGRATED NAVIGATION SYSTEM
INSTALLATION AND OPERATOR'S MANUAL

COM TRANSCEIVER STATUS

This message outputs the result of a specific system test.

Message format:

“V” Message class. This is a VHF NAV message.
“35” Message identifier.
mk Active frequency: m = MHz, where m = desired MHz frequency – 30h, ranging from 118 to 136 MHz, 162 (i.e., 76h to 88h, A2h); k = (kHz offset / 25 kHz) + 30h, ranging from 000 to 975 kHz steps.
mk Standby frequency: m = MHz, where m = desired MHz frequency – 30h, ranging from 118 to 136 MHz, 162 (i.e., 76h to 88h, A2h); k = (kHz offset / 25 kHz) + 30h, ranging from 000 to 975 kHz steps.
a..... Transceiver status:
 R = Normal receive
 T = Transmit enabled
 S = Stuck mic
 F = Comm failure
s..... Squelch test setting: (ASCII) 0 = automatic; 1 = test

Example message:

\$PMRRV35G4LFR0<chksm><LF>

Active frequency is 119.100 MHz, the standby frequency is 124.550 MHz, receiver function, squelch is automatic.

COM SOFTWARE VERSION

This message is used to output the version string for the VHF COM receiver software.

Message format:

“V” Message class. This is a VHF NAV message.
“36” Message identifier.
vvvv Software version in ASCII

Example message:

\$PMRRV300103<chksm><CR><LF>

COM software is version 1.03.

VOLUME AND SQUELCH SETTING

This command is sent anytime there is a change in either the volume or squelch settings, or is requested by using a Request Data Output "24" command.

Message format:

"V" Message class - VHF NAV Message
"71" Message Identifier
"vs" Volume level and Squelch Level:
 v = Desired volume level in encoded hexadecimal, where v = desired level + 0x30 with a range between 0 - 20, 0 being muted
 s = Desired squelch level in encoded hexadecimal, where s = desired level + 0x30 with a range between 0 - 20, 0 being off

Example Message:

\$PMRRV71;?<chksum><CR><LF>

This example command shows the volume level at 11 and the squelch at 15.

VAL AVIONICS LTD
INS 429 INTEGRATED NAVIGATION SYSTEM
INSTALLATION AND OPERATOR'S MANUAL

MIC GAIN AND SIDETONE

This command is sent anytime there is a change in either the volume or squelch settings, or is requested by using a Request Data Output "24" command.

Message format:

"V" Message class - VHF NAV Message

"72" Message Identifier

"ms" Volume level and Squelch Level:

m = mic gain level in encoded hexadecimal, where m = desired level + 0x30
with a range between 1 - 20

s = sidetone level in encoded hexadecimal, where s = desired level + 0x30
with a range between 1 - 20.

Example Message:

\$PMRRV72;?<checksum><CR><LF>

This example command shows the mic gain level at 11 and the sidetone at 15.